



REPUBLIC OF NAMIBIA



Ministry of Mines & Energy

MINISTRY OF MINES AND ENERGY
PROCUREMENT MANAGEMENT UNIT (PMU)

**Request for Quotations for Construction, Supply,
Delivery, Installation, and Testing of Property
Seismological Equipment Enclosure and
Emplacement (Re-Advertised)**

Procurement Reference No: W/RFQ/15-02/24/25

COMPANY NAME: _____

TOTAL BID PRICE: _____

BID PRICE IN WORDS: _____

CLOSING DATE AND TIME OF BID REQUEST:

DATE: **20 December 2024**

TIME: 10H00

Procurement Management Unit
Ministry of Mines and Energy
Head Office
6 Aviation Road
Windhoek Namibia

Tel: +264 61 284 8111 / 8235 / 8358

Fax: +264 61 235 632

Email: ProcurementManagement@mme.gov.na

Website: www.mme.gov.na

NB: Kindly attend the COMPULSORY SITE MEETING in KUNENE REGION: Erwee at the Ministry of Agriculture, Water and Forestry Office on Thursday 12 December 2024, at 10:00am – 11h00am) and the other site is at Damara Mopani Lodge, Gondwana on Thursday 12 December 2024 at 14h00am – 15h00am. Please confirm your attendance by sending an email to ProcurementManagement@mme.gov.na for more information, contact +264 61 284 8347. (Failure to attend the site visit will lead to an automatic disqualification). Bidders who attended the previous site meeting are not expected to attend this site inspection.



REPUBLIC OF NAMIBIA

REPUBLIC OF NAMIBIA
MINISTRY OF MINES AND ENERGY

Tel.: +264 61 284-8111
 Fax: +264 61 238643 / 220386
 E-mail: info@mme.gov.na
 Website: www.mme.gov.na

6 Aviation Road
 Private Bag
 13297
 WINDHOEK

Letter of Invitation

To:

Procurement Reference Number: W/RFQ/15-02/24/25

02 December 2024

Dear Sir, Madam

Request for Quotations for Construction, Supply, Delivery, Installation, and Testing of Property Seismological Equipment Enclosure and Emplacement

The Ministry of Mines and Energy invites you to submit your best quote for the works described in detail hereunder.

Any resulting contract shall be subject to the terms and conditions referred to in the document.

Queries, if any, should be addressed to ProcurementManagement@mme.gov.na

Please prepare and submit your quotation in accordance with the instructions given or inform the undersigned if you will not be submitting a quotation.

Yours faithfully,

 Head of Procurement Management
 Mr. Nathanie Musenga

MINISTRY OF MINES AND ENERGY PROCUREMENT MANAGEMENT UNIT
2024 -12- 02
PRIVATE BAG 13297 WINDHOEK NAMIBIA

SECTION I: INSTRUCTIONS TO BIDDERS

1. Rights of Public Entity

The **Ministry of Mines and Energy** reserves the right:

- (a) to split the contract as per the lowest evaluated cost per lot; and
- (b) to accept or reject any quotation or to cancel the quotation process and reject all quotations at any time prior to contract award.

2. Preparation of Quotations

You are requested to quote for the works mentioned in Section III, by completing, signing and returning:

- (a) the Quotation Letter in Section II with its annex for Bid Securing Declaration, where applicable;
- (b) the Priced Activity Schedule in Section IV;
- (c) the Specifications and Compliance Sheet in Section V; and
- (d) any other attachment as deemed appropriate

You are advised to carefully read the complete Request for Quotations document, including the Special Conditions of Contract in Section VII, before preparing your Quotation. The standard forms in this document may be retyped for completion but the Bidder is responsible for their accurate reproduction.

3. Validity of Quotations

The quotation validity period shall be **30 days** from the date of bid submission deadline.

4. Eligibility Criteria

To be eligible to participate in this Quotation exercise, you should:

- a) have a valid certified company Registration Certificate; (certified by the Namibian Police or Commission of Oath)**
- b) have an original valid good Standing Tax Certificate; (certified by the Namibian Police or Commission of Oath)**
- c) have an original valid good Standing Social Security Certificate. (certified by the Namibian Police or Commission of Oath)**
- d) have a valid certified copy of Affirmative Action Compliance Certificate, proof from Employment Equity Commissioner that bidder is not a relevant employer, or exemption issued in terms of Section 42 of the Affirmative Action Act, 1998; (certified by the Namibian Police or Commission of Oath)**

- e) Provide a minimum of three (3) contactable references letters of similar work done in construction.
- f) Attach documentary evidence for work completed such as completion certificates at least a minimum of (3), all completion certificates must be accompanied by corresponding award letters/Purchase Orders.
- g) All pages of the bidding documents should be initialled where possible.
- h) Submit a duly filled in bid document.
- i) **NB!!!! COMPULSORY SITE VISIT ON THE DATES BELOW:**

NB: Kindly attend the COMPULSORY SITE MEETING in KUNENE REGION: Erwee at the Ministry of Agriculture, Water and Forestry Office on Thursday 12 December 2024, at 10:00am – 11h00am) and the other site is at Damara Mopani Lodge, Gondwana on Thursday 12 December 2024 at 14h00am – 15h00am. Please confirm your attendance by sending an email to ProcurementManagement@mme.gov.na for more information, contact +264 61 284 8347. (Failure to attend the site visit will lead to an automatic disqualification). Bidders who attended the previous site meeting are not expected to attend this site inspection.

Bid Security/Bid Securing Declaration

Bidders are required to submit a Bid Securing Declaration for this procurement process.

5. Delivery

Delivery shall be 60 days after acceptance/issue of Purchase Order. Deviation in delivery period shall not be accepted.

6. Sealing and Marking of Quotations

Quotations should be sealed in a single envelope, clearly marked with the Procurement Reference Number, addressed to the **Ministry of Mines and Energy** with the Bidder's name at the back of the envelope.

7. Submission of Quotations

Quotations should be deposited in the Quotation/Bid Box located at 6 Aviation Road, Ground Floor, Block F1, not later **20 December 2024 at 10h00**. Quotations by post or hand delivered should reach 6 Aviation Road by the same date and time at latest. Late quotations will be rejected.

Quotations received by e-mail will not be considered.

8. Opening of Quotations

Quotations will be opened internally by the Public Entity immediately after the closing time referred to in section 8 above. A record of the

Quotation Opening stating the name of the bidders, the amount quoted, the presence or absence of a Bid Security/Bid Securing Declaration, will be posted on the website of the Public Entity and available to any bidder on request within three working days of the Opening.

9. Evaluation of Quotations

The Public Entity shall have the right to request for clarifications in writing during evaluation. Offers that are substantially responsive shall be compared on the basis of evaluated cost, subject to Margin of Preference where applicable, to determine the lowest evaluated quotation.

Table 1 Mandatory Requirements

Document Description	Yes/No
<ul style="list-style-type: none"> • A valid certified copy by the Namibian Police of a Company Registration Certificate or Registration of defensive name if applicable and the Founding Statement in the case of a CC (certified copies not more than 3 months old). All entities must be incorporated in Namibia. 	
<ul style="list-style-type: none"> • All bidders must be 100% Namibian owned company, proof of Identity Documents / Passports of company directors certified by the Namibian Police must be attached. (Certified copies not more than 3 months older at the date of submission) 	
<ul style="list-style-type: none"> • A valid original or certified copy by the Namibian Police of Good Standing Tax Certificate. 	
<ul style="list-style-type: none"> • A valid original or certified copy by the Namibian Police of Good Standing Social Security Certificate. 	
<ul style="list-style-type: none"> • A valid original or certified copy by the Namibian Police of Affirmative Action Compliance Certificate or in its absence, proof from the Employment Equity Commissioner that the Bidder is not a relevant employer, or exemption issued in terms of Section 42 of the Affirmative Action Act, 1998. 	
<ul style="list-style-type: none"> • A duly completed and signed Bid Securing Declaration Form. 	
<ul style="list-style-type: none"> • All pages of the Bid Document are initialled. Failure leads to disqualification of the bidder. 	
<ul style="list-style-type: none"> • An undertaking on the part of the Bidder that salaries and wages payable to its personnel in respect of this proposal are compliant to the relevant laws, remuneration order and award, where applicable and that it will abide to sub-clause 602 of the GCC if it is awarded the contract or part thereof. 	
<ul style="list-style-type: none"> • Bid validity period 30 days. 	
Proof of at least a minimum three (3) practical completion certificates shall be attached and failure will lead to disqualification .	
<ul style="list-style-type: none"> • MME reserves the right to verify the legality of the attached completion 	

certificates by directly contacting the Consulting Firms and Clients. MME will verify the authenticity of the completion certificates that is attached on the bidding document by directly contact Consulting Firms and Clients. Completion certificates without contact details of the issuing authority will be deemed invalid.	

10. Technical Compliance

The Specifications and Compliance Sheet details the minimum specifications of the works to be carried out. The specifications have to be met, but no credit will be given for exceeding the specifications.

11.1 Technical Evaluation

The following criteria/technical requirement shall apply during evaluation process:

(a) Adequacy of Technical Proposal

Evaluation of the Bidder's Technical Proposal will include an assessment of the Bidder's technical capacity to mobilize key equipment and personnel for the contract consistent with its proposal regarding work methods, scheduling, and material sourcing in sufficient detail and fully in accordance with the requirements stipulated in Section V (Employer's Requirements).

For Bids to be deemed substantially responsive, in addition to the provisions of the Instructions to Bidders, the must obtained a **Yes** from the different categories listed in the table below. Bids obtaining a **NO** will be deemed non-responsive and will not be further considered.

Table 2 **Technical Requirements**

Document Description	Yes/No
<ul style="list-style-type: none"> Project Manager with 3 years' experience in construction work or electrical. Project Manager should possess a diploma in Construction Management or Electrical level 6, or National Diploma in Civil Engineering/Electrical level 6, or N6 technical qualification on construction/ Civil Engineering/Electrical. Attach CV and certified copy of the qualifications. 	
<ul style="list-style-type: none"> Site Foreman with 3 years' experience as an electrician. Trade Diploma/Certificate (Minimum N3 certificate) as a qualified electrician (provide CV and qualifications, ID, or Passport). Attach certified copy of the qualification and ID. 	
<ul style="list-style-type: none"> Key Personnel with 3 years' experience in welding or boiler making, a Trade Diploma/Certificate (Minimum N3 certificate) in Welder or Boiler Maker. (Provide CV and qualifications, ID, or Passport). 	
<ul style="list-style-type: none"> Experience on occupational health, safety, and environment 	

Management. Availability of documented HSE policy or Availability of Certificate for Safety Officer.	
<ul style="list-style-type: none"> • Proof of ownership of a 4 x 4 pick-up (attach a certified copy of a valid license disc certificate), or proof of lease for a 4 x 4 pick-up (attach a lease agreement). 	

11. Prices and Currency of Payment

Prices for the execution of works shall be fixed in Namibian Dollars as quoted.

12. Margin of Preference

12.1. The applicable margins of preference and their application methodology are as follows: The margin of preference is applicable to this request for this Bid is |: **Preference will only be granted to bidders as per Government notice No: 13 in terms of the code of good practice issued on 31 January 2023 in terms of section 71 and 72 of the Public Procurement Act, 2015 and Public Procurement Act,2022 as amended.** The maximum cumulative allowable margin of preference applicable to exclusive preferences for price evaluation purposes is **10%**. Kindly see the table below.

12.2. Bidders applying for the Margin of Preference shall submit, upon request, evidence of: Applicable Exclusive Preference.

Margins of preferences when evaluating bids for Exclusive Preference

Category	Margin of preference	Documentary evidence
Manufacturer	2 percent	-Certificate of registration from a registering authority -Declaration by the bidder that the manufactured goods meet the local content as determined in Annexure 6 as per the cost structure for Value Added Calculation in Annexure 1, and as certified by an Accountant
MSME	1 percent	-SME registration certificate -Declaration indicating the percentage of Namibian MSME ownership
Women owned	1 percent	- IDs of all shareholders -Founding statement/company registration

enterprise		indicating ownership structure/shareholder certificate - declaration indicating the percentage of Namibian female ownership
Youth owned enterprise	2 percent	- IDs of all shareholders - Founding statement/company registration indicating ownership structure/shareholder certificate - declaration indicating the percentage of Namibian youth ownership
PDP owned enterprise	2 percent	-IDs of all shareholders - Founding statement/company registration indicating ownership structure/shareholder certificates - declaration indicating the percentage of Namibian PDPs ownership
Supplier promoting environmental protection	1 percent	-declaration and proof that the bidder meets the requirements set out in the bidding document
Service rendered by Namibian citizens.	1 percent	-declaration that the bidder employs 50% or more Namibian citizens
Total	10%	

13. Award of Contract

The Bidder having submitted the lowest evaluated responsive quotation and qualified to perform the works shall be selected for award of contract. Award of contract shall be by issue of a Purchase Order/Letter of Acceptance in accordance with terms and conditions contained in Section VI: Contract Agreement and General Conditions of Contract.

14. Notification of Award and Debriefing

The Public Entity shall after award of contract promptly inform all unsuccessful bidders (on Bidder request) in writing of the name and address of the successful bidder and the contract amount. Furthermore, the Public Entity shall attend to all requests for debriefing made in writing within 7 days of the unsuccessful bidders being informed of the award.

SECTION II: QUOTATION LETTER

(to be completed by Bidders)

[Complete this form with all the requested details and submit it as the first page of your quotation with the Priced Activity Schedule and documents requested above. A signature and authorisation on this form will confirm that the terms and conditions of the RFQ prevail over any attachments. **If your quotation is not authorised, it will be rejected**

Quotation addressed to: [name of Public Entity]	
Procurement Reference Number:	
Subject matter of Procurement:	

We offer to execute the Works detailed in the Statement of Requirements, in accordance with the terms and conditions stated in your Request for Sealed Quotations referenced above.

We confirm that we are eligible to participate in this Quotation exercise and meet the eligibility criteria specified in Section 1: Instructions to Bidders

We undertake to abide by the Conduct of Bidders and Suppliers as provided under the Public Procurement Act during the procurement process and the execution of any resulting contract.

We have read and understood the content of the Bid Security/Bid Securing Declaration (BSD) attached hereto and subscribe fully to the terms and conditions contained therein. We further understand that this subscription could lead [forfeiture of the security amount / disqualification on the grounds mentioned in the BDS]

The validity period of our Quotation is _____ days [insert number of days] from the date of the bid submission deadline.

We confirm that the prices quoted in the Priced Activity Schedule are fixed and firm and will not be subject to revision or variation, if we are awarded the contract **prior to the expiry** date of the quotation validity.

Works will commence within _____ [insert number] days from date of issue of Purchase Order/ Letter of Acceptance.

Works will be completed within _____ [insert number] days from date of issue of Purchase Order/ Letter of acceptance.

Quotation Authorised by:

Name of Bidder		Company's Address and seal	
Contact Person			
Name of Person Authorising the Quotation:		Position:	Signature:
Date		Phone No./E-mail	

**BID SECURING DECLARATION
(Section 45 of Act)
(Regulation 37(1) (b) and
37(5))**

Date:

Procurement Ref No.:

To:

I/We* understand that in terms of section 45 of the Act a public entity must include in the bidding document the requirement for a declaration as an alternative form of bid security.

I/We* accept that under section 45 of the Act, I/we* may be suspended or disqualified in the event of

- (a) a modification or withdrawal of a bid after the deadline for submission of bids during the period of validity;**
- (b) refusal by a bidder to accept a correction of an error appearing on the face of a bid;**
- (c) failure to sign a procurement contract in accordance with the terms and conditions set forth in the bidding document, should I/We* be successful bidder; or**
- (d) failure to provide security for the performance of the procurement contract if required to do so by the bidding document.**

I/We* understand this bid securing declaration ceases to be valid if I am/We are* not the successful Bidder

Signed:
[insert signature of person whose name and capacity are shown]

Capacity of:
[indicate legal capacity of person(s) signing the Bid Securing Declaration]

Name:
[insert complete name of person signing the Bid Securing Declaration]

Duly authorized to sign the bid for and on behalf of: [insert complete name of Bidder]

Dated on _____ day of _____
[insert date of signing]

Corporate Seal (where appropriate)
[Note*: In case of a joint venture, the bid securing declaration must be in the name of all partners to the joint venture that submits the bid.]

***delete if not applicable / appropriate**



Republic Of Namibia

Ministry of Labour, Industrial Relations and Employment Creation

Written undertaking in terms of section 138 of the Labour Act, 2015 and section 50(2)(D) of the Public Procurement Act, 2015

1. EMPLOYERS DETAILS

Company Trade Name:.....

Registration Number :.....

Vat Number:

Industry/Sector:

Place of Business:.....

Physical Address:.....

Tell No.:.....

Fax No.:.....

Email Address:.....

Postal Address:.....

Full name of Owner/Accounting Officer:.....

.....

Email Address:.....

2. PROCUREMENT DETAILS

Procurement Reference No.:.....

Procurement Description:

.....
.....

Anticipated Contract Duration:

Location where work will be done, good/services will be delivered:

.....

3. UNDERTAKING

I[insert full name], owner/representative

of[insert full name of company]

hereby undertake in writing that my company will at all relevant times comply fully with the relevant provisions of the Labour Act and the Terms and Conditions of Collective Agreements as applicable.

I am fully aware that failure to abide to such shall lead to the action as stipulated in section 138 of the labour Act, 2007, which include but not limited to the cancellation of the contract/licence/grant/permit or concession.

Signature:

Date:

Seal:.....

Please take note:

1. A labour inspector may conduct unannounced inspections to assess the level of compliance
2. This undertaking must be displayed at the workplace where it will be readily accessible and visible by the employees rendering service(s) in relations to the goods and services being procured under this contract.

SECTION III: STATEMENT OF REQUIREMENTS

- **Specification for Construction, Supply, Delivery, Installation, and Testing of Property Seismological Equipment Enclosure and Emplacement**
 - **(See Annexure A: Terms of Reference)**

SECTION IV: PRICED ACTIVITY SCHEDULE

Procurement Reference Number: **W/RFQ/15-02/24/25**

[Complete the unit and total prices for each item listed below. Authorise the prices quoted in the signature block below.]

The quantities shown below are approximate and not subject to re-measurement for payment purposes.

Item No	Brief Description of Works	Quantity	Unit of Measure	Unit Price (N\$)	Total Price (N\$)
A*	B*	C*	D*	E	F
1.	Request for Quotations for Construction, Supply, Delivery, Installation, and Testing of Property Seismological Equipment Enclosure and Emplacement As per Section III	1	EACH		
Subtotal					
VAT @ %					
Total					

Enter 0% VAT rate if VAT exempt.

*Columns A to D to be completed as applicable by the Public Entity

Priced Activity Schedule Authorised By:

Name:		Signature:	
Position:		Date:	
Authorised for and on behalf of:		Company	

SECTION V: SPECIFICATIONS AND COMPLIANCE SHEET

[Public Entity shall customise this section and the table hereunder where the Service Providers have to achieve set specification and performance standards.]

Procurement Reference Number: **W/RFQ/15-02/24/25**

[Bidders should complete columns C and D with the specifications and performance of the Works offered. Also state "comply" or "not comply" and give details of any non-compliance/deviation to the specifications required. Attach detailed technical literature if required. Authorise the specifications offered in the signature block below]

Item No	Specifications and Performance Required	Compliance of Specifications and Performance Offered	Details of Non-Compliance/ Deviation (if applicable)
A*	B*	C	D
1.	As per section IV		

* Columns A and B to be completed by Public Entity.

Specifications and Compliance Sheet Authorised By:

Name:		Signature:	
Position:		Date:	
Authorised for and on behalf of:		Company	

SECTION VI: GENERAL CONDITIONS OF CONTRACT AND CONTRACT AGREEMENT

Any resulting contract shall be placed by means of a Purchase Order/Letter of Acceptance and shall be subject to the General Conditions of Contract (GCC) for the Procurement of Goods (Ref. **W/RFQ/15-02/24/25**) available on the website of the Public Entity (www.mme.gov.na) except where modified by the Special Conditions below.

Additional terms and conditions

- ✓ Workforce to be equipped with the necessary health, safety and any other related accessories.
- ✓ It is solely the responsibility of the contracted Bidder to ensure that the place of work is left clean and in order.
- ✓ Any damage that may arise as a result of negligence of the contracted company, the contracted company will be liable for the costs e.g. wall/boards. Any damage caused to the existing structure by the contractor, the contractor shall be solely liable for the cost and repairs of such damage.
- ✓ The Bidders are required to ensure safety of their employees performing the requested services and SHALL NOT hold the ministry liable for any injury/ies/death that may occur during the performance of this service,
- ✓ Bidders MUST provide proof of work done of a similar nature together with the submission of this bid.
- ✓ Bidders MUST provide protective clothing for their employees to protect them from risks pertaining to their health and safety as per HSE certification.
- ✓ Bidders are strictly required to adhere to the terms and conditions as outlined in the bidding document and may not access or perform on unpermitted areas.

SECTION VIII SPECIAL CONDITIONS OF CONTRACT

Procurement Reference Number: **W/RFQ/15-02/24/25**

The clause numbers given in the first column correspond to the relevant clause number of the General Conditions of Contract (GCC).

Clause	Contract Data
GCC 1.1 Effectiveness of Contract	The Contract shall come into effect as from receipt of Purchase order/Award letter.
GCC 1.3.1 Intended Completion date	Unless terminated earlier pursuant to sub-clause GCC 1.7 of the Contract, the Service Provider shall complete its activities by
GCC 1.6.1 Issue of notices	The Authorized Representative of the Employer is : Mr. Nathaniel Musenge The Authorized Representative of the Service Provider is: _____
GCC 2.6 Insurance and liabilities to Third Party	The amount of the Professional Indemnity Insurance Cover shall be at least: N/A
GCC 2.7 Reporting Obligations	The Service Provider shall report to: Mr. Nathaniel Musenge Head of Procurement Management Unit, 6 Aviation Road , Windhoek
GCC 2.10 Performance Security	The Performance Security shall be for an amount [5 to 10 %] of the Contract Price or part thereof if the contract is awarded on a split basis. N/A
GCC 4.2 Contract Price	The amount payable is: Attached on quotation
GCC 4.3 Terms of Payment	Payments will be made to the Service Provider once off 30 days after receipt of invoice.
GCC 4.5 Price Adjustment	Prices shall not be adjustable.

QUOTATION CHECKLIST SCHEDULE

[Public Entity to update this Checklist to ensure that it contains the documents required from Bidders for the specific procurement]

Procurement Reference No.:

Description	Attached	Not Attached
Quotation letter		
Priced Activity Schedules		
Specification and Compliance Sheet		
Original valid good Standing Tax Certificate; (certified by Namibian police)		
Original valid good Standing Social Security Certificate; (certified by Namibian police)		
Certified copy of Affirmative Action Certificate or proof of Employment Equity		
Signed Bid Securing Declaration		
Signed undertaking in terms of labour act		
Copy of company registration certificate		

Disclaimer: *The list defined above is meant to assist the Bidder in submitting the relevant documents and shall not be a ground for the bidder to justify its non-submission of major documents for its quotation to be responsive. The onus remains on the Bidder to ascertain that it has submitted all the documents that have been requested and are needed for its submission to be complete and responsive.*

ANNEXURE A:**SPECIFICATION FOR CONSTRUCTION, SUPPLY,
DELIVERY, INSTALLATION AND TESTING OF
PROPRIETRY SEISMOLOGICAL EQUIPMENT
ENCLOSURE AND EMPLACEMENT**

1. INTRODUCTION.

The Geological Survey of Namibia runs an ongoing expansion project of Namibia's National Seismological Network with the aim of improving the national seismic network coverage. The Geophysics Division under the Geological Survey of Namibia operates and manages the National Seismological Network of Namibia. The main objective of the seismological network is to record and monitor seismic occurrences countywide and regionally in order to identify areas that are prone and vulnerable to earthquake activities for hazard mitigation and civil scientific applications.

2. SCOPE OF WORK.

Namibia Seismological Network has ten permanent stations. The network is used to monitor the general seismicity of the country, perform special seismic studies and it used to help mitigate the country's seismic risk over a long period of time. Considering the enormous size of Namibia, adding to the seismological network will increase the seismic coverage of Namibia. This small coverage lead to large spatial errors of earthquake events and also magnitude determination is problematic. This will allow us to have data exchange locally and internationally. This would also allow us to do collaborative studies in environmental monitoring and seismic hazard assessment.

The construction will be for two (2) permanent station that will be added to existing seismological network to improve seismic coverage of Namibia. The construction of the station can be constructed by local or international companies.

The work to be undertaken may be summarised as follows:

3.1 Clearing of identified site.

- Clear scrubs and trees inside the identified area
- Clear scrubs and trees outside the identified area to a radius of 5m from vault and housing (if necessary)

3.2 Insulated Equipment Housing

- Insulated container internal dimensions W1000mm x H800mm x D700mm (if solar panel is to be mounted on top, dimensions can be adjusted to fit solar panel)
- Sides, roof, and floor: thickness: 50mm. Color: White
- Door: double hinged door with 1-point lock
- Sub-frame: mild steel structural subframe with extended 1,1-meter-high adjustable leveling legs
- Wooden shelf installed inside

- 400mm din-rail installed above shelf
- Two opening cuts into floor and shelf
- 12v 105Ah battery for each station x2 (AGM)
- 100-watt Solar panel for each station: Mounted on the pole
- Teltonika RUT955 Router
- Circuit-breakers
- Housing slab

3.3 Seismic Vault Construction

- Depending on the depth of the bedrock, excavation to the bedrock will be required. 2 m below ground unless bedrock is found at a shallower depth. (minimum depth 1m)
- Blasting is not allowed
- Construct a concrete pier, with a diameter of 1 meter and 150 mm thick coupled to the bedrock
- Cement for the pier should be 40 MPa in strength (watertight): Molded material
- A ditch is to surround the pier
- At least 15 mm distance between pier and vault walls
- HDPE material, UV resistance, corrosive resistance that can withstand underground pressure
- Drill 50mm hole, at least 200mm from top of rings, through both inner and outer ring and install 50mm PVC pipe for cable to the seismometer. Make sure to seal the hole where the pipe comes through the concrete. (This pipe must go directly into the station hut which must be within 2.5meter from the edge of the vault)
- Exposed parts of the vault should be painted white. Vault is to be painted white inside and outside.
- Vault should have a ladder inside
- Ventilation pipe option
- Vault entry should be compacted with rocks for at least 1 meter with stairs to the opening

3.4 Vault Lid

- Molded HDPE material lid 5 mm thick, and a lid to cover the vault lid to prevent water from entering the vault
- Should be painted white with heat reflective paint
- It should be 500mm above ground
- A rubber gasket between vault entrance and lid is to be installed.
- Ensure that the lid is watertight
- Make sure that lid has 25mm lips that will fit precisely over the outer ring ensuring that no water from the surface will get into the vault. (Paint lid white or silver to reflect most heat)
- Vault cover should be firmly fixed with a locking mechanism
- Vault cover door with a handle for opening and closing

3.5 Fencing off the Station

- 4 m X 4 m fencing around the station
- 2.1 m high fence to be erected around the station
- 4 corner posts to be erected
- Razor mesh for vertical fencing, and flat razor blades.
- Razor wire to be installed for overhang
- 1.8 m X 900 mm Gate, with razor wire above gate
- 200 mm X 300 mm of 25 MPa edge beam

NB: Please note that the successful bidder is expected to provide their own, personnel, material, water, and electricity supply for this work.

4. CLARIFICATIONS.

CLARIFICATION REGARDING ASPECTS OF THIS TENDER CAN BE ADDRESSED TO:

The Procurement Management Unit

Private Bag 13297

Windhoek

NAMIBIA

Tel - 264 (0) 61 2848111/8435

Enquiries should refer to 'CONSTRUCTION, SUPPLY, DELIVERY, INSTALLATION AND TESTING OF PROPRIETRY SEISMOLOGICAL EQUIPMENT ENCLOSURE AND EMPLACEMENT'

E-mail addresses: Procurement.Management@mme.gov.na

5. APPENDIX.

a. Top View schematic of the Seismic Station

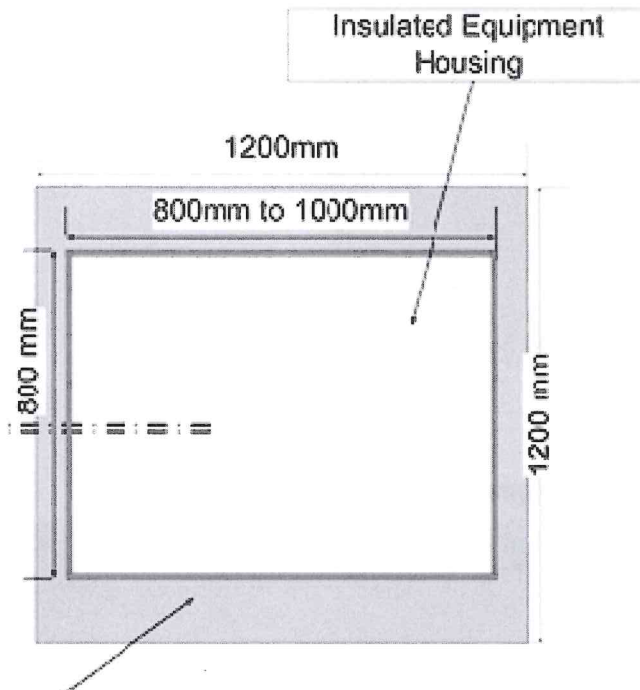

Figure 1: Top view schematic of seismic station

b. Side View schematic of the Seismic Station

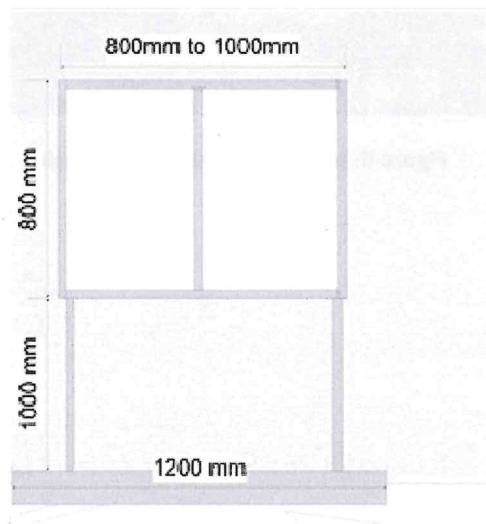

Figure 2: side view of seismic station

c. Seismic Vault Overview

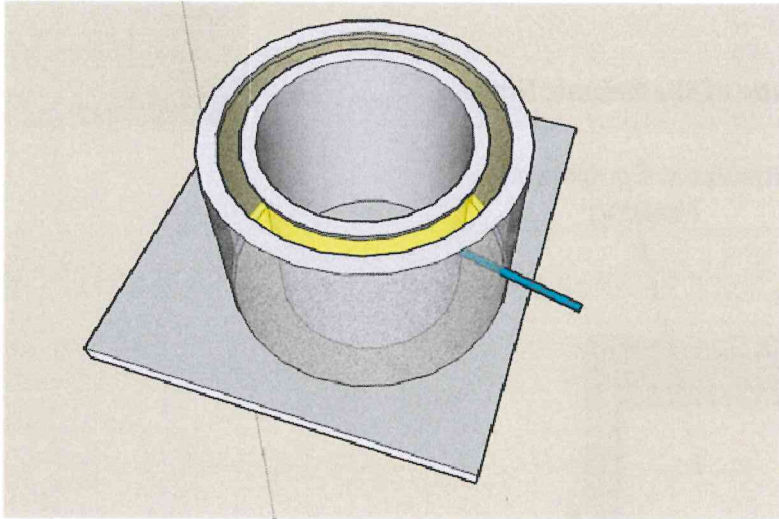

Figure 3: Seismic vault overview

d. Complete Station and inside of Equipment Housing



Figure 4: Complete seismic station



Figure 5: Inside the equipment housing



Figure 6: Complete fenced off station